

UNCONTROLLED DOCUMENT

SC:0.25

PART NUMBER

SSL-LXA228SRD

REV.

B

UNDER REVISION

REV.	E.C.N. NUMBER AND REVISION COMMENTS	DATE
A	E.C.N. #10541.	8.3.99
B	E.C.N. #10743.	5.31.01

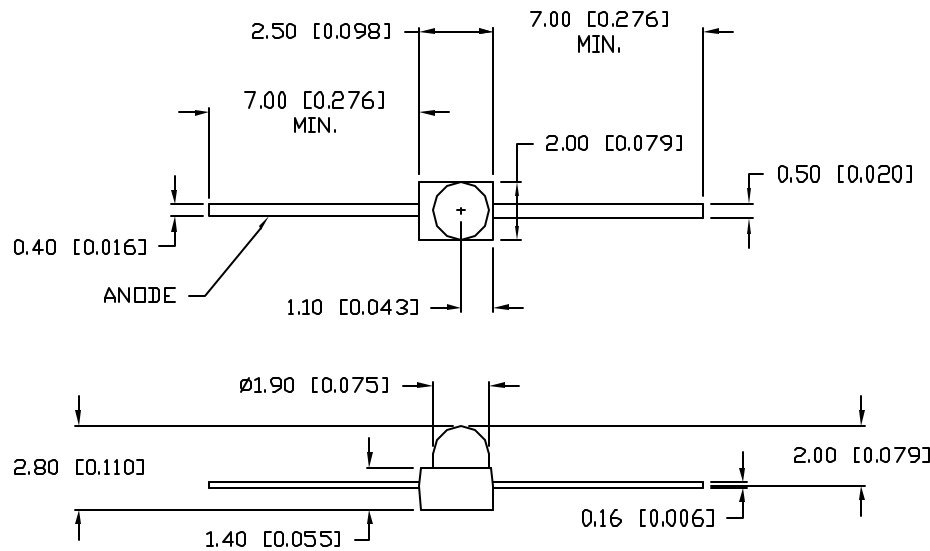

Ⓜ ELECTRO-OPTICAL CHARACTERISTICS  $T_A=25^{\circ}\text{C}$   $I_f=20\text{mA}$

PARAMETER	MIN	TYP	MAX	UNITS	TEST COND
PEAK WAVELENGTH		650		nm	
FORWARD VOLTAGE		2.0	2.5	$V_f$	
REVERSE VOLTAGE	5.0			$V_r$	$I_f=100\mu\text{A}$
AXIAL INTENSITY		100		mcd	$I_f=20\text{mA}$
VIEWING ANGLE		50		2x theta	
EMITTED COLOR:	SUPER RED				
EPOXY LENS FINISH:	RED DIFFUSED				

Ⓜ LIMITS OF SAFE OPERATION AT  $25^{\circ}\text{C}$

PARAMETER	MAX	UNITS
PEAK FORWARD CURRENT*	160	mA
Ⓜ STEADY CURRENT	25	mA
POWER DISSIPATION	60	mW
DERATE FROM $25^{\circ}\text{C}$	-1.2	mW/ $^{\circ}\text{C}$
OPERATING, STORAGE TEMP.	-40 TO +85	$^{\circ}\text{C}$
SOLDERING TEMP.	+260	$^{\circ}\text{C}$
2mm FROM BODY		3 SEC. MAX

\*  $t < 10\mu\text{S}$

UNCONTROLLED DOCUMENT

\*UNLESS OTHERWISE SPECIFIED TOLERANCES PER DECIMAL PRECISION ARE: X=±1 (±0.039), XX=±0.5 (±0.020), XXX=±0.25 (±0.010), XXXX=±0.127 (±0.005). LEAD SIZE=±0.05 (±0.002), LEAD LENGTH=±0.75 (±0.030). MIN= +DECIMAL PRECISION -0.00, MAX.= +0.00 -DECIMAL PRECISION

REV. B	PART NUMBER SSL-LXA228SRD
T-2.5mm AXIAL LEADED LED, 650nm SUPER RED LED, RED DIFFUSED LENS.	

**CONFIDENTIAL INFORMATION**  
THE INFORMATION CONTAINED IN THIS DOCUMENT IS THE PROPERTY OF LUMEX INC. EXCEPT AS SPECIFICALLY AUTHORIZED IN WRITING BY LUMEX INC., THE HOLDER OF THIS DOCUMENT SHALL KEEP ALL INFORMATION CONTAINED HEREIN CONFIDENTIAL AND SHALL PROTECT SAME IN WHOLE OR IN PART FROM DISCLOSURE AND DISSEMINATION TO ALL THIRD PARTIES.

**RELIABILITY NOTE**  
OUR MANY YEARS OF EXPERIENCE DATA ACCUMULATION INDICATE THAT SOLDER HEAT IS A MAJOR CAUSE OF EARLY AND FUTURE FAILURE. PLEASE PAY ATTENTION TO YOUR SOLDERING PROCESS.

		290 E. HELEN ROAD PALATINE, IL 60067-6976 PHONE: +1.847.359.2790 US WEB: www.lumex.com TW WEB: www.lumex.com.tw
DRAWN BY: CT	CHECKED BY:	APPROVED BY:
DATE: 10.4.95	PAGE: 1 OF 1	SCALE: N/A